

Eclipse AirHeat Burners

Model AH
Version 2

Parameter	Specifications	
Maximum Input, BTU/hr/lf (kW/m)¹ <i>Contact factory for chamber pressures outside the given range, or varying chamber pressure conditions.</i>	1,000,000 (961)	
Minimum Input, BTU/hr/lf (kW/m)¹	25,000 (24,5)	
Fuel Inlet Pressure, "w.c. (mbar) <i>Natural gas pressure at gas inlet (Tap B)</i>	8.7 (22)	
High Fire Flame Length, inch (mm)² <i>Measured from the burner outlet.</i>	43 (1100)	
Upstream Temperature Limit, °F (°C)	Packaged Blower ³	-40 to 104°F (-40 to 40°C)
	Remote Blower, Standard Body	-40 to 500°F (-40 to 260°C)
	Remote Blower, SS Body	-40 to 750°F (-40 to 400°C)
Downstream Temperature Limit, °F (°C)	321 SS Wings	1300°F (704°C)
	330 SS Wings	1500°F (815°C)
Flame Detection	Flame rod or UV scanner	
Ignition	Direct Spark Ignition ⁴ Spark Ignited Pilot ⁵	
Fuels <i>For any other mixed gas, contact Eclipse Inc.</i>	Natural Gas, Propane, Butane ⁶	

¹ At Neutral Conditions and Δp Air = 1.0" w.c. (2.5 mbar) Δp air is measured between tap A and tap C (see page 5 for tap locations).

² Based on typical parallel process air flow. If mounted in a cross flow, flame will be shorter.

³ Based on blower motor limitations

⁴ Direct spark ignition is possible up to 60% of maximum rated input.

⁵ Pilot input is approximately 25,000 BTU/hr (7.3 kW).

⁶ See Design Guide 135 for more information about typical fuel composition and properties.

- All inputs are based on gross calorific values and standard conditions: one atmosphere, 70°F (21°C).
- All information is based on laboratory testing in neutral (0.0" w.c.) chamber. Different chamber size and conditions will affect data.
- Blower motor service factors greater than 1.0 may be required when firing into negative chamber pressure applications. For specific application questions, contact Eclipse.
- Eclipse reserves the right to change the construction and/or configurations of our products at any time without being obliged to adjust earlier supplies accordingly.

Performance Graphs

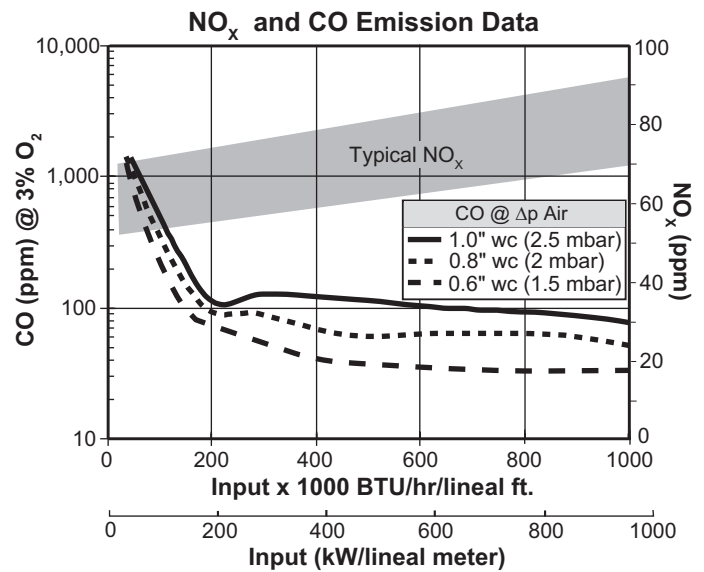
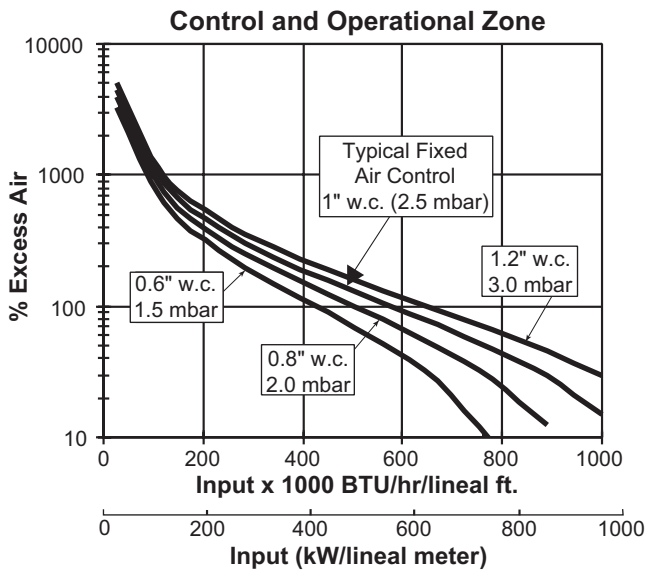

Notes on Control and Operational Zone

This graph shows the amount of excess air through the burner at various Δp air settings and as a function of the input. At lower excess air levels, complete combustion will require sufficient O₂ in the process air flow.

Contact Eclipse with details on your application.

NO_x and CO emission data is given for:

- Ambient combustion air (~70°F, 20°C)
- Minimal process air velocity
- Neutral chamber pressure
- Natural gas

Emissions are influenced by:

- Chamber conditions
- Fuel type
- Firing rate

CO emissions are largely influenced by chamber conditions. Contact your local Eclipse representative for an estimate of CO emissions on your application.

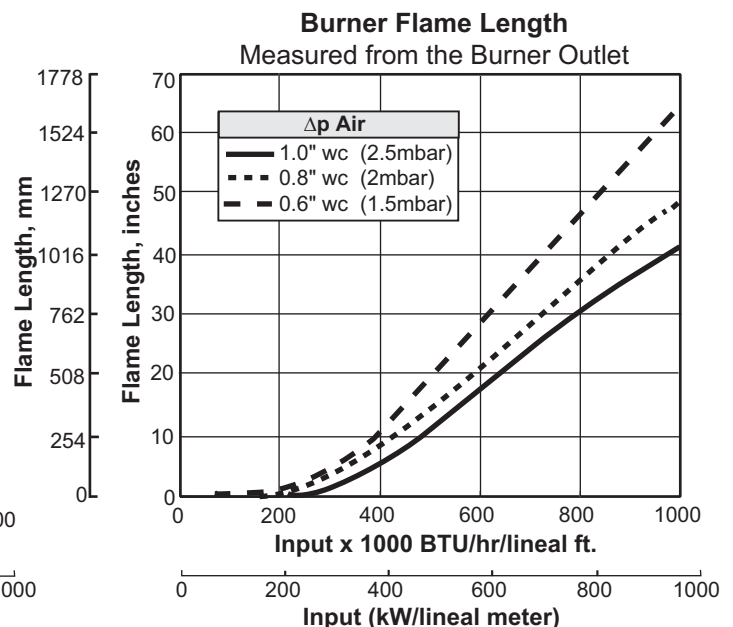
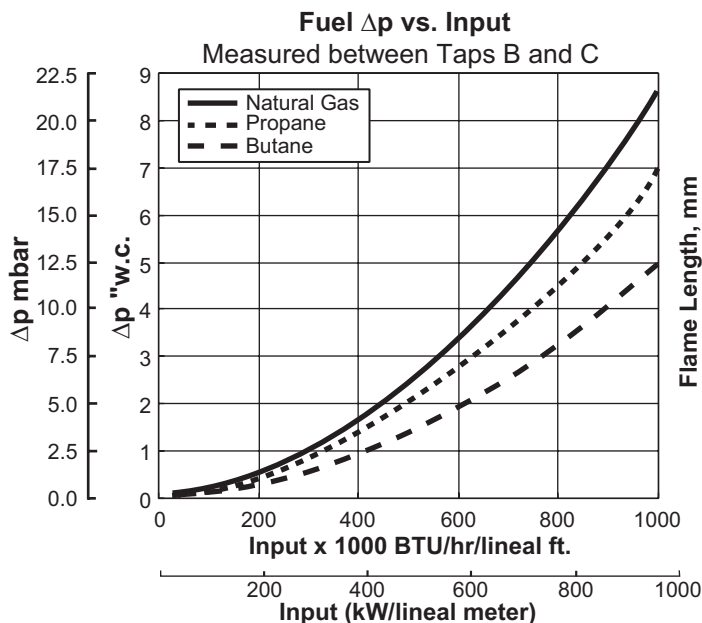

Process Flow Considerations

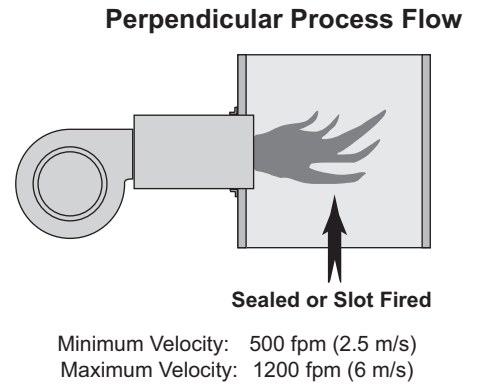
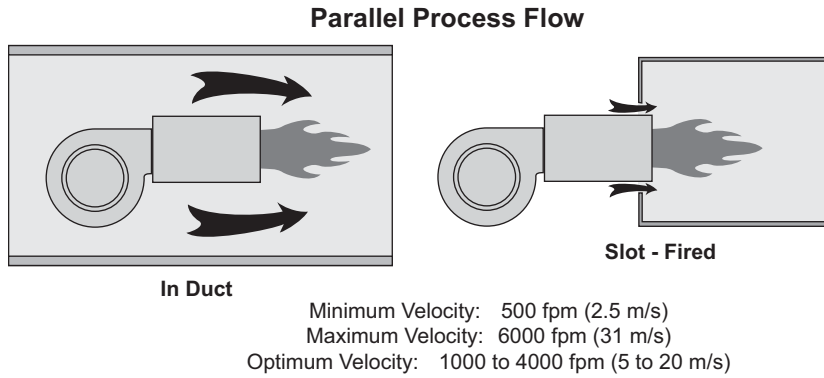

Dimensions & Specifications

Dimensions in inches (mm)

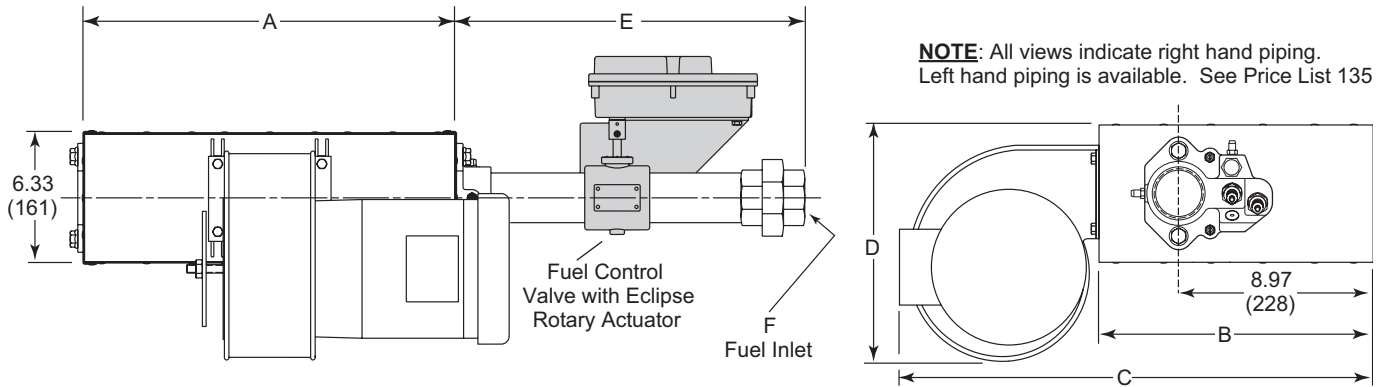

Burner Model	Max. Input MM BTU/hr	Inches									Pipe Thread			Cross Sect. Area in ²	Approx Ship Wt lb
		A	B	60 Hz Blower		50 Hz Blower		Natural Gas	Propane	Butane	Natural Gas	Propane	Butane		
				C	D	C	D	E	E	E	F	F	F		
AH0050	0.5	6.10	12.72	21.42	10.91	21.89	13.62	16.06	16.06	16.06	1	1	1	39	42
AH0100	1.0	12.01	12.72	21.42	10.91	21.89	13.62	16.65	16.06	16.06	1-1/2	1	1	76	49
AH0150	1.5	17.91	12.72	21.42	10.91	21.89	13.62	16.65	16.65	16.06	1-1/2	1-1/2	1	114	57
AH0200	2.0	23.82	12.72	23.35	14.80	21.14	13.74	16.65	16.65	16.65	1-1/2	1-1/2	1-1/2	151	77
AH0250	2.5	29.72	12.72	23.35	14.80	21.14	13.74	16.65	16.65	16.65	1-1/2	1-1/2	1-1/2	188	85
AH0300	3.0	35.63	12.72	23.35	14.80	21.65	15.24	16.73	16.65	16.65	2	1-1/2	1-1/2	226	92
AH0350	3.5	41.54	12.72	23.35	14.80	21.65	15.24	16.73	16.65	16.65	2	1-1/2	1-1/2	263	100
AH0400	4.0	47.44	12.72	23.35	14.80	21.65	15.24	16.73	16.73	16.65	2	2	1-1/2	301	107

Burner Model	Max. Input kW	mm									Pipe Thread			Cross Sect. Area cm ²	Approx Ship Wt kg
		A	B	60 Hz Blower		50 Hz Blower		Natural Gas	Propane	Butane	Natural Gas	Propane	Butane		
				C	D	C	D	E	E	E	F	F	F		
AH0050	147	155	323	544	277	556	346	408	408	408	Rc1.0	Rc1.0	Rc1.0	250	19
AH0100	293	305	323	544	277	556	346	423	408	408	Rc1.5	Rc1.0	Rc1.0	491	22
AH0150	440	455	323	544	277	556	346	423	423	408	Rc1.5	Rc1.5	Rc1.0	733	26
AH0200	586	605	323	593	376	537	349	423	423	423	Rc1.5	Rc1.5	Rc1.5	974	35
AH0250	733	755	323	593	376	537	349	423	423	423	Rc1.5	Rc1.5	Rc1.5	1216	39
AH0300	879	905	323	593	376	550	387	425	423	423	Rc2.0	Rc1.5	Rc1.5	1457	42
AH0350	1026	1055	323	593	376	550	387	425	423	423	Rc2.0	Rc1.5	Rc1.5	1699	45
AH0400	1172	1205	323	593	376	550	387	425	425	423	Rc2.0	Rc2.0	Rc1.5	1940	49

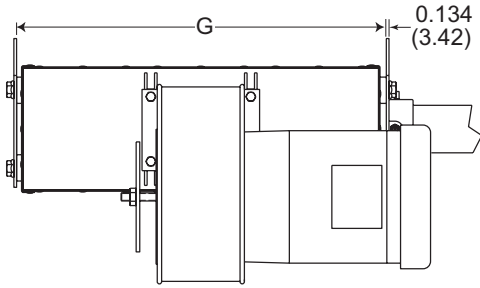

Duct Mounting

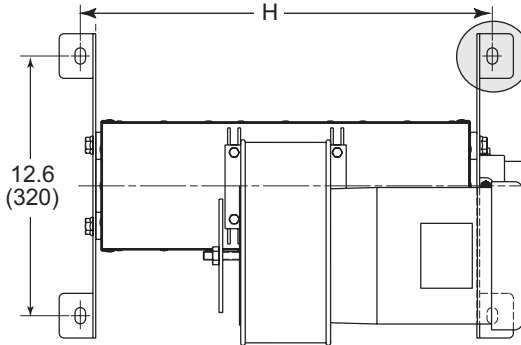
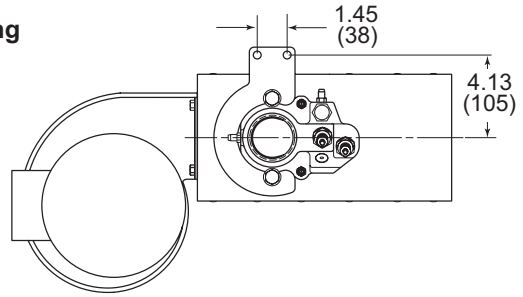

Slot Firing

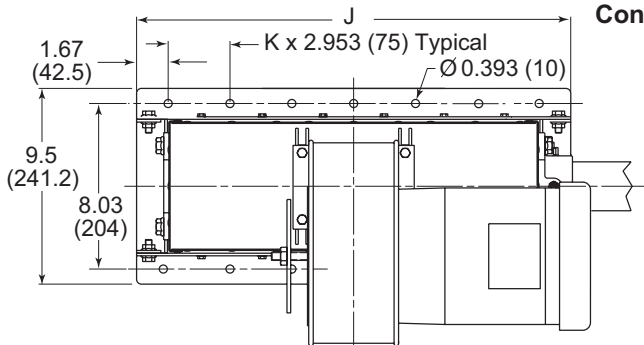
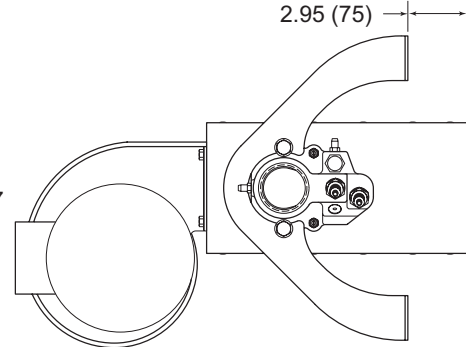
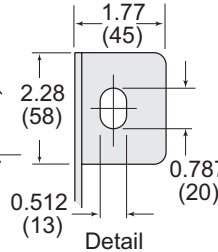

Continuous Mounting

Configurator Flange Option "C" 2.95 (75)
Configurator Flange Option "F" 4.13 (105)

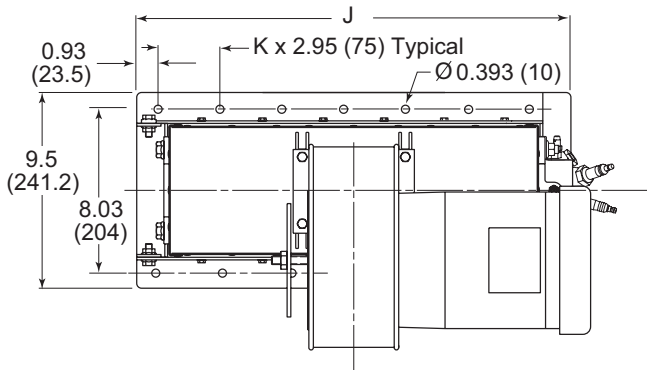
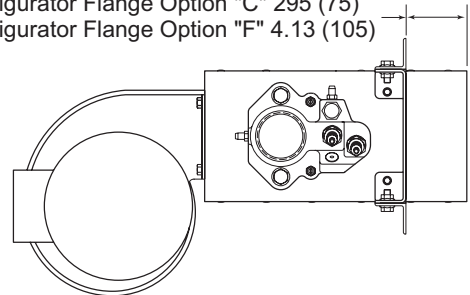

Continuous Mounting 6" Insertion

Configurator Flange Option "G" 6.00 (152.4)

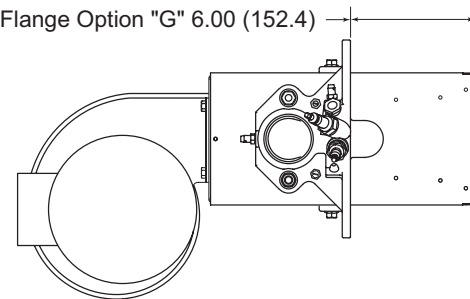

Burner Model	mm			K	Inches			K
	G	H	J		G	H	J	
AH0050	169.7	207.7	235	2	6.68	8.18	9.25	2
AH0100	319.7	357.7	385	4	12.59	14.08	15.16	4
AH0150	469.7	507.7	535	6	18.49	19.99	21.06	6
AH0200	619.7	657.7	685	8	24.40	25.89	26.97	8
AH0250	769.7	807.7	835	10	30.30	31.80	32.87	10
AH0300	919.7	957.7	985	12	36.21	37.70	38.78	12
AH0350	1069.7	1107.7	1135	14	42.11	43.61	44.69	14
AH0400	1219.7	1257.7	1285	16	48.02	49.52	50.59	16

Combustion Air Inlet

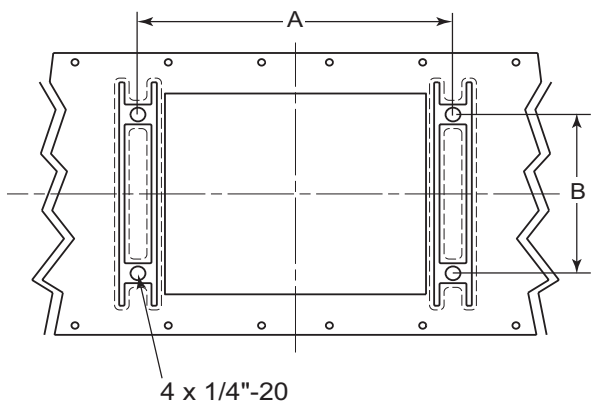

Burner Model	mm		inches	
	A	B	A	B
AH0050	127.0	82.3	5.00	3.24
AH0100	127.0	82.3	5.00	3.24
AH0150	127.0	82.3	5.00	3.24
AH0200	185.7	101.6	7.31	4.00
AH0250	185.7	101.6	7.31	4.00
AH0300	185.7	101.6	7.31	4.00
AH0350	185.7	101.6	7.31	4.00
AH0400	185.7	101.6	7.31	4.00

End Plates

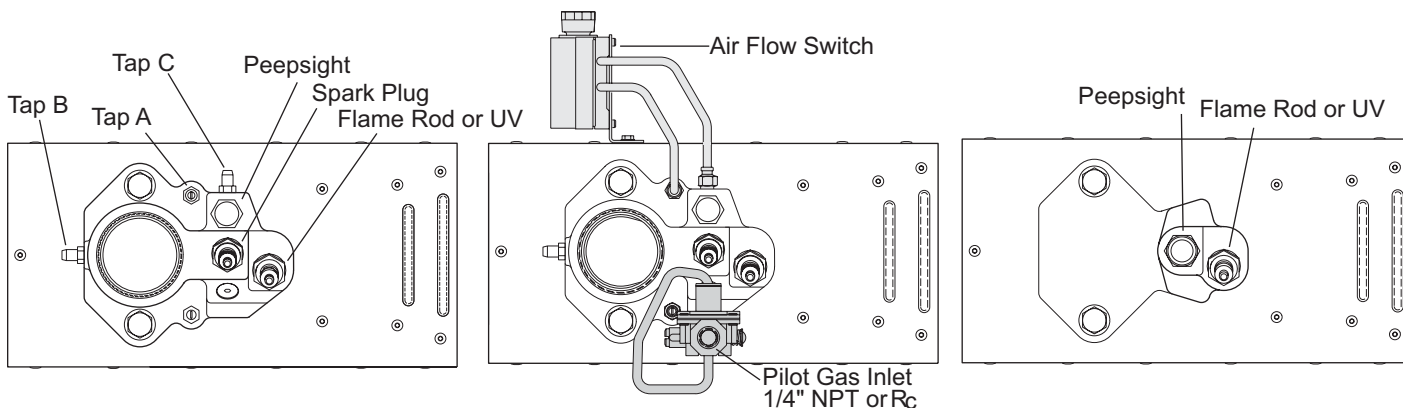

Separate Spark and Flame Rod

Optional Spark Ignited Pilot and Air Flow Switch

Optional Flame Monitoring End Plate and Flange

Continuous Mounting 6" Insertion

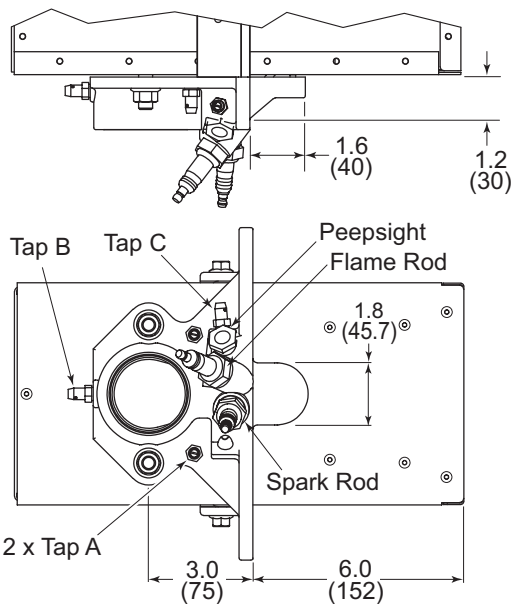

Recommended Oven Wall Cut-Out with 6" Insertion Flange

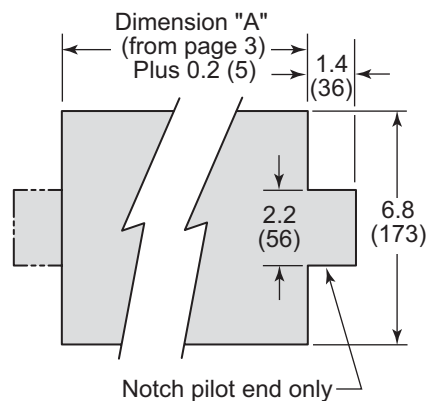

Combustion Air Blowers

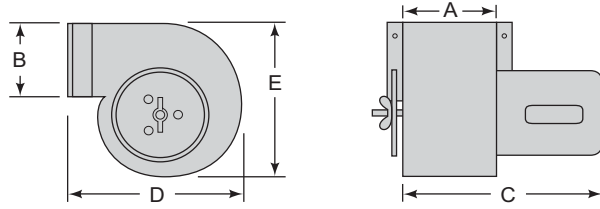

60 Hz Blowers

Used with Blower Cat. No.	Blower Cat. No.	Asy. No.	Rotor No.	Capacity CFH	Static Press "w.c.*	TEFC 230/460/60		
						HP	RPM	Part No.
AH0050 thru AH0150	54-54S-1/3	109410	16328	20,000	1.90	1/3	3450	12109**
AH0200 thru AH0300	65-84S-1/3	109241	16706	43,000	1.50	1/3	1750	12110
AH0350 thru AH0400	66-94S-3/4	109243	10539-1	63,000	2.00	3/4	1750	11803

50 Hz Blowers

Used with Blower Cat. No.	Blower Cat. No.	Asy. No.	Capacity CFH	Static Press "w.c.*	Motor			
					kW	RPM	Part No.	Specifications
AH0050 thru AH0100	MN 402	101293	20,000	1.2	0.25	2850	20519	230/440/3/50
AH0150 thru AH0250	MN 502	101294	42,400	1.6	0.37	2850	20520	230/440/3/50
AH0300 thru AH0400	MN 602	101295	74,200	1.6	1.10	2850	20523	230/440/3/50

* Additional capacity at reduced pressure. Static pressure measured at blower outlet using American Fan Association Standards.

** TENV Motor

60 Hz Blower

Dimensions inches (mm)	Blower Catalog Number		
	54-564S-1/3	65-84S-1/3	66-94S-3/4 66-94S-1
A	4.00 (102)	6.06 (154)	6.06 (154)
B	4.12 (105)	5.06 (129)	6.31 (160)
C 1/3 HP	12.25 (311)	14.62 (371)	-
C 3/4 HP	-	-	15.50 (394)
D	8.31 (211)	12.93 (329)	15.00 (381)
E	8.62 (219)	13.75 (349)	15.50 (394)
Wt. Lbs. (kg)	6.4 (3)	19.5 (9)	24.0 (11)

50 Hz Blower

Dimensions inches (mm)	Blower Catalog Number		
	MN 402	MN 502	MN 602
A	4.33 (110)	4.33 (110)	5.51 (140)
B	5.12 (130)	6.30 (160)	7.48 (190)
C	11.61 (295)	12.52 (318)	15.15 (385)
D	8.78 (223)	10.75 (273)	13.30 (338)
E	10.63 (270)	12.68 (322)	15.94 (405)
Wt. Lbs. (kg)	6.4 (3)	19.5 (9)	24.0 (11)

NOTE: Weight does not include motor.

Filters For AirHeat Burners

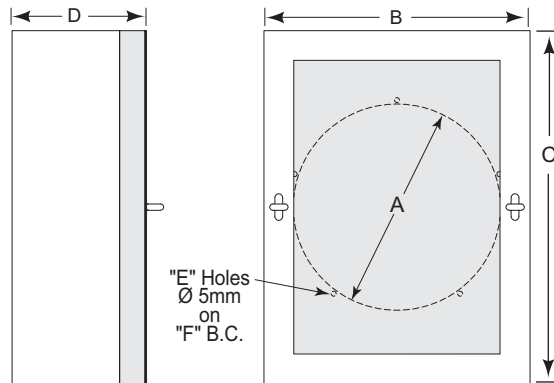

Blower Size	Used on Burner Size	Filter Cat. No.	Filter Asy. No.	Filter Media Asy. No.	Dimensions inches (mm)					
					A	B	C	D	E	F
54-54S	50 thru 150	2 AHFS	10009319	10009322	6.0 (150)	8.5 (216)	11.7 (298)	4.3 (110)	4	6.5 (165)
65-84S	200 thru 300	3 AHFS	10009261	10009271	8.0 (208)	10.5 (267)	14.0 (356)	5.3 (135)	5	8.5 (216)
66-94S	350 thru 400	4 AHFS	10009262	10009272	9.5 (241)	14.0 (356)	20.0 (508)	5.5 (141)	5	10.0 (254)



Offered By:

Power Equipment Company
2011 Williamsburg Road
Richmond, Virginia 23231
Phone (804) 236-3800
Fax (804) 236-3882

www.peconet.com